

APPLICATION NOTE APNE-0015

Electric Fields and Fieldmeters in Web Converting

Table of Contents

I. Introduction	2
Content	2
Review	2
II. Electric Fields and Fieldmeters.....	2
Electric Field	2
Electric Fieldmeters	3
Effect of Probe Type on Fieldmeter Readings	5
Investigation of High Electric Field Problem Areas with Handheld Fieldmeters.....	6
Effect of Operator Presence on Fieldmeter Readings.....	8
Taking Handheld Fieldmeter Measurements	8
Calculating web surface charge density.....	14
Relating web surface charge density to the real world.....	14
Continuous monitoring of electric fields in high-risk machine/product performance areas.....	14
III. References	15

I. Introduction

Content

This document provides the reader with a review of how fieldmeters operate to measure electric fields, the effects of web-converting machine geometry and operator techniques when measuring electric fields, how handheld fieldmeters are used to investigate where static problem areas exist on machines, and techniques for interpreting fieldmeter readings.

This document is the second in a series of three application notes about static charging of materials and equipment in web converting machines, including recommendations for static measurement, control, and continuous monitoring. The first document in this series is application note *APNE-0014 Electrostatic Charging In Web Converting*.

Review

Generation and control of static in web converting depends upon many varying conditions in the web material, the converting machine, the surrounding atmosphere, and the static control measures used on the machine. It is impossible to predict and control all of these conditions because they can change without one realizing it until a statically caused event occurs. Changing conditions can alter the amount of static charge accumulation, so although static is under control today, it may not be under control tomorrow.

The keys to continuous static control are

- (1) The correct determination of critical areas of the machine to monitor for static charge accumulation,
- (2) Application of static countermeasures and devices that prevent or control static charge accumulation, and
- (3) Continuous electric field measurement in these critical areas using permanent fieldmeters, which are alarmed to warn or shutdown the operation when web static charge levels increase beyond predetermined set points.

II. Electric Fields and Fieldmeters

Electric Field

An electric field is a region of space characterized by the existence of an electric force (F) generated by an electric charge (q). The electric force F acting on a charge q in an electric field is proportional to the charge itself. The relationship of these quantities is expressed by the electrostatic force law [1]:

$$F = qE$$

E is called the electric field strength and is determined by the magnitude and locations of the other charges acting upon charge q :

$$E = F/q$$

The electric field strength, E , is usually displayed in the unit of volt/meter (V/m), volt/centimeter (V/cm) or volt/inch (V/in).

Electric Fieldmeters

Charge is often difficult or impossible to measure directly. We rely on detection and measurement of the electric field from the charged object to determine the existence of the charge and to estimate its magnitude. The electrostatic fieldmeter is the instrument that measures electric field strength.

Electric field strength measurements can be difficult to measure and interpret correctly because of several factors that can affect the electric field itself or affect the measurement of the electric field. Guidance is given in this document to help understand or minimize the effects of these factors, and to otherwise correctly interpret electric field measurements.

Fieldmeters measure the electrostatic field (voltage per unit distance) at the aperture of a grounded probe. Ideally, a uniform electric field is established between a charged surface and a grounded surface. The grounded surface may be the grounded surface of the fieldmeter probe, or the fieldmeter probe may also be placed in the plane of a grounded surface (better). The electric field is set up between the grounded surface and the charged surface some distance, D , away. Fieldmeters are calibrated at a particular distance, such as V/inch or V/cm. Therefore, using the manufacturer's calibrated distance (one inch or one centimeter) makes the measurement easier to interpret. Probe-to-surface separation should be carefully controlled for accurate measurement.

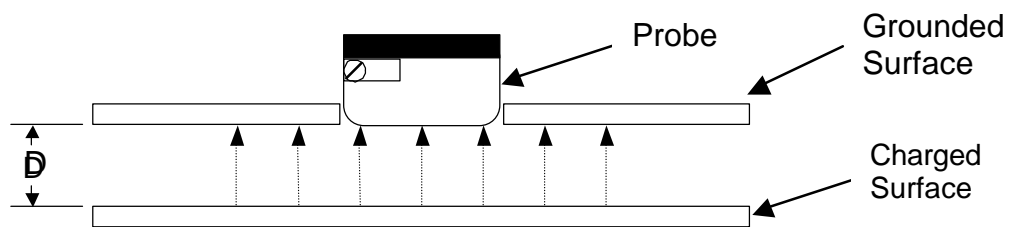

Figure II-1

Probe-to-Charged-Surface Separation, D

Monroe Electronics' electrostatic fieldmeters use a feedback-driven, null seeking design to assure accurate, drift-free, non-contacting measurements. Accuracy is typically 2% to 5% in a carefully controlled geometry.

Figure II-2 illustrates a Monroe Electronics Model 1036 fieldmeter probe in simple graphical form. This particular fieldmeter is a chopper-stabilized design that operates reliably in both ionized and non-ionized environments. The probe can be physically

located at the desired measurement location, while the instrumentation portion of the fieldmeter is remotely located. Because of its 'intrinsically safe' (IS) rating, the probe can operate continuously in hazardous (explosive) environments provided that it is installed according to Monroe Electronics' instructions, and used with the approved intrinsic safety barriers.

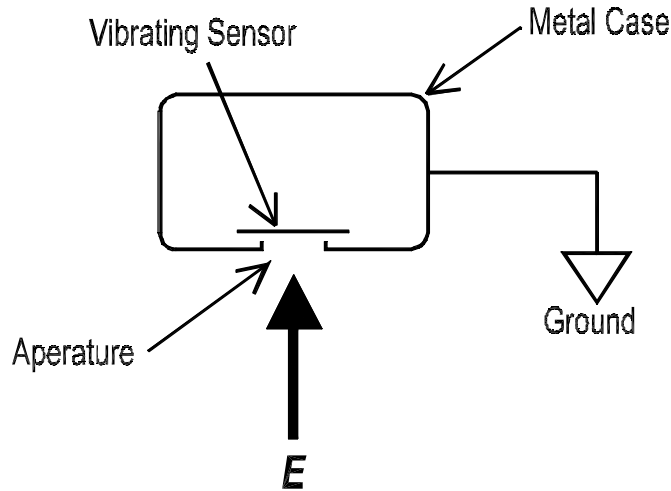

Figure II-2

Monroe Model 1036 Fieldmeter Probe

Electrostatic fieldmeters measure electric field strength by non-contacting means. All the charged objects, voltage sources, and grounded conductors (including the fieldmeter probe housing) in the general area affect the electric field strength measurement. The fieldmeter measures the electric field strength only at its aperture. It does not have a viewing angle and it does not see the web or object directly in front of it as a separate entity. This can be demonstrated by measuring the electric field of an insulating sheet with a hole in it.

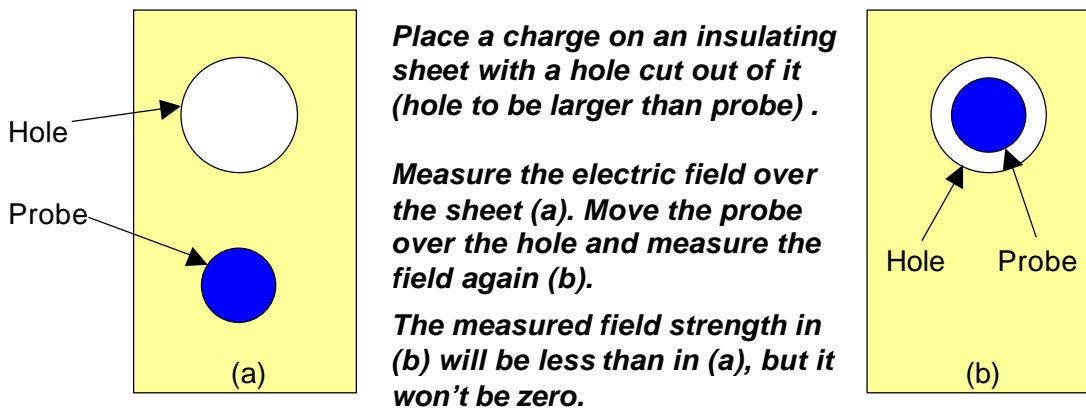

Figure II-3

Insulating Sheet Electric Field Demo, Top View

The field over the hole will not be zero even though there is no charge directly in front of the probe head. This is because the electric field at the probe aperture is a function of each charge on the sheet, and is also a function of the concentration of field due to the grounded probe itself.

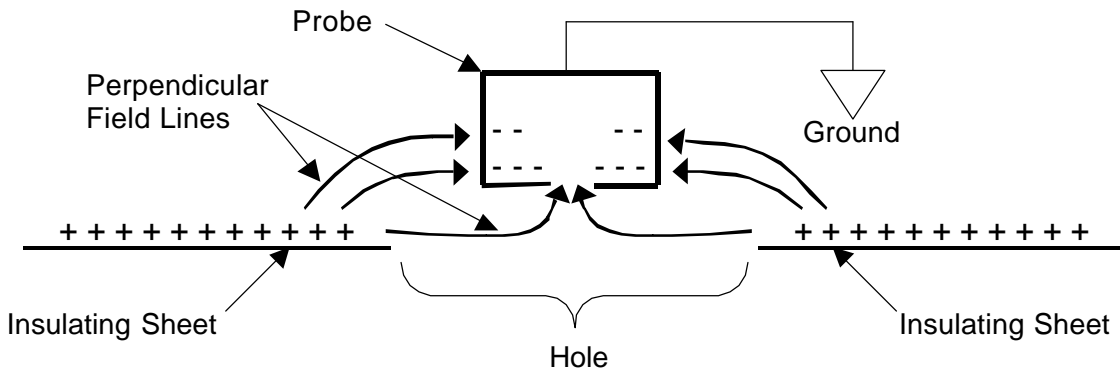

Figure II-4

Insulating Sheet Electric Field Demo, Front View of Figure II-3(b)

Effect Of Probe Type On Fieldmeter Readings

For measurement of insulating web surfaces, it is best to maintain the same distance from the fieldmeter to the web as when the fieldmeter was calibrated. Since most fieldmeters are calibrated at one inch, their apertures should be positioned one inch from the web while measurements are taken. Accurate readings can be obtained using the Monroe Electronics 265A and 282A handheld fieldmeters as-is, provided the web is wide enough and there are no nearby grounds or other charged surfaces to influence the electric field.

The situation is more complex for the Monroe Electronics Models 257D and 177A fieldmeters, which both use the Model 1036 probes[3]. The Model 1036 probes are primarily used for permanent installations once the high-field locations have been determined using one of the handheld meters. The Model 1036E probe will give accurate readings (as-is) at a measurement distance of one inch because its large grounded face helps to create a uniform electric field near the aperture of the probe.

The Model 1036F probe is significantly smaller than the Model 1036E probe. Unless a grounded shroud is used to enlarge the smaller ground plane of the 1036F probe, the fieldmeter readings will be about 12% high because the electric field will converge on the small probe[3]

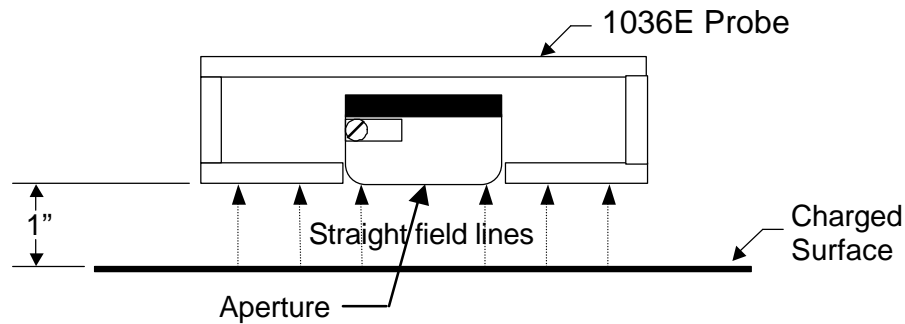

Figure II-5
Field Lines Straight to 1036E Probe

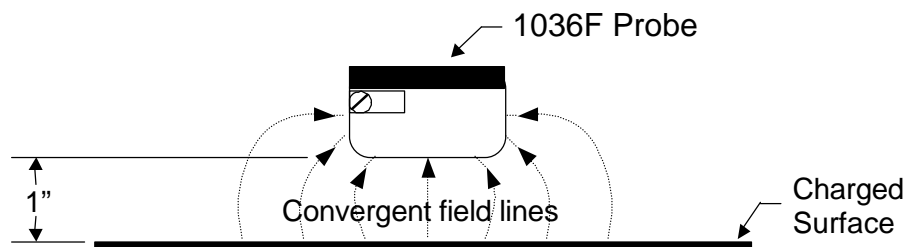

Figure II-6
Field Lines Converging to 1036F Probe

Investigation Of High Electric Field Problem Areas With Handheld Fieldmeters

Unless the humidity of a web converting machine area is controlled to 50-60% RH, the highest electric fields tend to be found during 'worst case' humidity conditions such as the driest winter months. The typical indoor humidity of industrial buildings is usually less than 15% RH during these periods, and the opportunity of obtaining the most meaningful electric field data is at its best.

It may already be apparent where high electric field problem areas exist on a web-converting machine due to previous incidents such as fires, shocks to people, web transfer problems and/or poor product quality. However, new problems areas may appear due to changes in raw materials, environmental conditions, machine mechanical components, etc. The locations and electric field strength of problem areas should be determined and recorded using portable fieldmeters.

Monroe Electronics manufactures several portable fieldmeters that are capable of easily and accurately determining high-field problem areas. Two fieldmeters that are recommended for surveying web converting machines are the Monroe Electronics Models 265A and 282A. (See also Application Note APNE-0012, *Comparison of Monroe Electronics' Handheld Fieldmeters.*) **Best** - For accuracy, ease of use, and



flammable atmospheres

The Monroe Electronics Model 282A Digital Stat-Arc 2™ Electrostatic Fieldmeter features the highest available accuracy (5%) and voltage resolution (10 volts) in a hand-held fieldmeter. The Model 282A also features a ranging system, consisting of two pulsing LED's, that show the operator when the fieldmeter is being held one inch from the target surface. It includes a HOLD button to capture and hold the readings made at locations where the display cannot be viewed during the measurement. An intrinsically safe version of the Model 282A, which is the Model 282IS, is rated for use in many hazardous environments.



Good – For a less expensive option in nonflammable atmospheres

The Model 265A Stat-Arc™ II Electrostatic Fieldmeter features excellent accuracy (10%) and voltage resolution (100V). It features a very wide measurement range up to 30kV/inch, with two scales and two ranges (1X, 10X) to automatically indicate the true electric field strength regardless whether the instrument is held one inch or four inches from the target surface.

Both the Model 282A and 265A are chopper stabilized for drift-free operation, even in ionized environments.

™ StatArc is a registered trademark of Monroe Electronics, Inc.

Effect of Operator Presence on Fieldmeter Readings

Fieldmeters are calibrated in fixtures without a person holding them, so the effect of the grounded operator holding the fieldmeter probe while taking measurements must be minimized. For best results, handheld fieldmeters, such as the Monroe 265A and 282A, should be held by the operator's outstretched arm and away from the body so as to minimize the effect of the body on the measurement. The fieldmeter should be held in such a way that the fieldmeter is closer to the web than is the arm or body of the operator.

Taking Handheld Fieldmeter Measurements

Several factors must be considered before and during the measurement process to obtain accurate readings for analysis. Figure II-7 below and the decision chart that follows provide the necessary guidance.

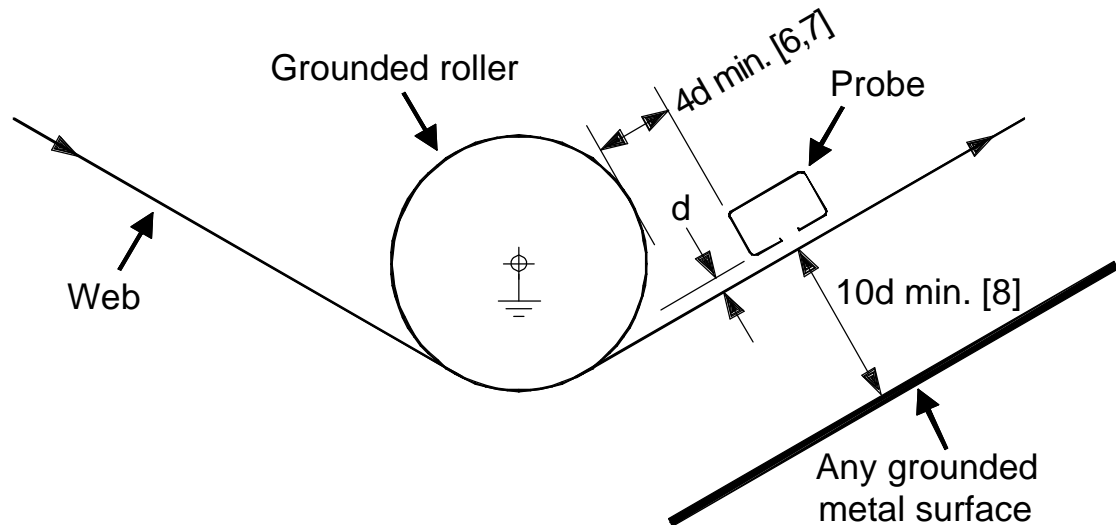

Figure II-7

Minimum Distances of Probe to Grounded Rollers and Surfaces

Notes on using the simple “net charge” static survey decision chart:

Decision Chart Page 1:

All insulating materials are ‘transparent’ to electric fields, so it is not possible to distinguish on which side of an insulating sheet the charges are located (when measured in free space) [4]. Only the average charge (net charge) can be measured by a fieldmeter. Fortunately, net charge is usually the quantity we are looking for on a charged insulator.

“Bound” charges within the volume of the insulator are also included in the net charge measured by the fieldmeter. Bound charges are most likely to be

generated by:

Different chemical and/or mechanical properties of the starting web top and bottom surfaces.

Conductive layer(s) placed on or inside the web, as with metal foil coatings.

Corona discharge treatment (CDT) of the web at any time during its life cycle.

Pinch roller operation, as when the web runs over a metal gravure cylinder with a rubber impression roller applying pressure to the cylinder.

One must be careful that a high 'bound' charge is not captured within the insulator, lest a condition for highly energetic propagating brush discharges be established [4,9].

Bound charge investigation requires the use of a properly shielded electrostatic voltmeter (see www.monroe-electronics.com/esd_pages/voltmeters.htm) in addition to a fieldmeter, and is best left to an expert.

Decision Chart Page 2:

Typical locations for verifying low web fields are at hazardous operations such as rotogravure solvent printing. Measure electric fields after the last grounded roller (or after any ionizer), but before the gravure printing roller, and then after the gravure roller (or after any ionizer), but before the next grounded roller.

High fields that are causing electrostatic discharges (ESD) in a moving web-converting machine can be quickly located by moving along the machine holding a portable AM radio tuned off-station in an unused frequency band. The static heard over the speaker or headphones will increase near the ESD locations, and may produce a discrete popping noise. The radio picks up the static discharges because they generate broadband electromagnetic radiation.

Decision Chart Page 3:

For fields beginning to exceed $\pm 10\text{kV/in}$ (using the 10X range of the Model 265A fieldmeter), move the Model 265A to four inches from the web and observe the reading. Use the lower, ± 3000 scale of the meter to obtain the actual field strength, up to $\pm 30\text{kV/in}$. If the reading on the 265A begins to exceed $\pm 30\text{kV/in}$ at four inches, then a Model 282A fieldmeter must be used.

For fields beginning to exceed $\pm 20\text{kV/in}$ on the Model 282A fieldmeter, move the Model 282A to four inches from the web and observe the reading. Multiply the reading by a factor of two to obtain the actual field strength, up to $\pm 40\text{kV/in}$. If the reading on the 282A begins to exceed $\pm 20\text{kV/in}$ at four inches, back off to 6.5 inches and multiply the reading by 3 to obtain the result, up to $\pm 60\text{kV/in}$. If the reading on the 282A begins to exceed $\pm 60\text{kV/in}$ at 6.5 inches, back off to 8.5 inches and multiply the reading by 4 to obtain the result, up to $\pm 80\text{kV/in}$. Keep in mind that the available web target size specified in Note 5 needs to increase by a factor of 4 times **d**.

For both the 265A and 282A fieldmeters, the minimum distances shown in Figure II-7 must increase by the indicated factor times the measurement distance, **d** (Note 1 & Note 2). These minimum distances must be maintained to prevent conductive, grounded surfaces from suppressing the electric field.

Simple "Net Charge" Static Survey

Page 1

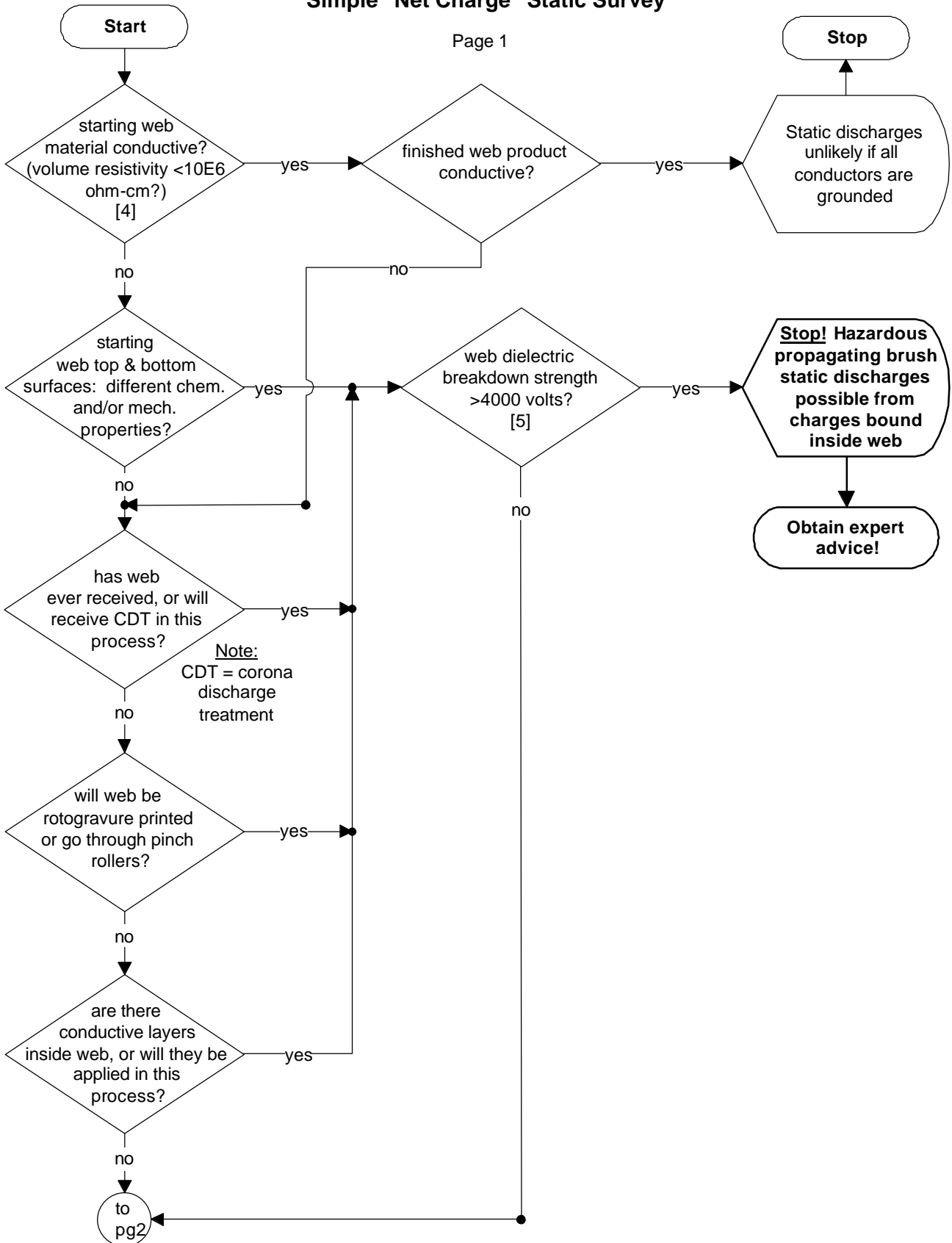

Simple "Net Charge" Static Survey

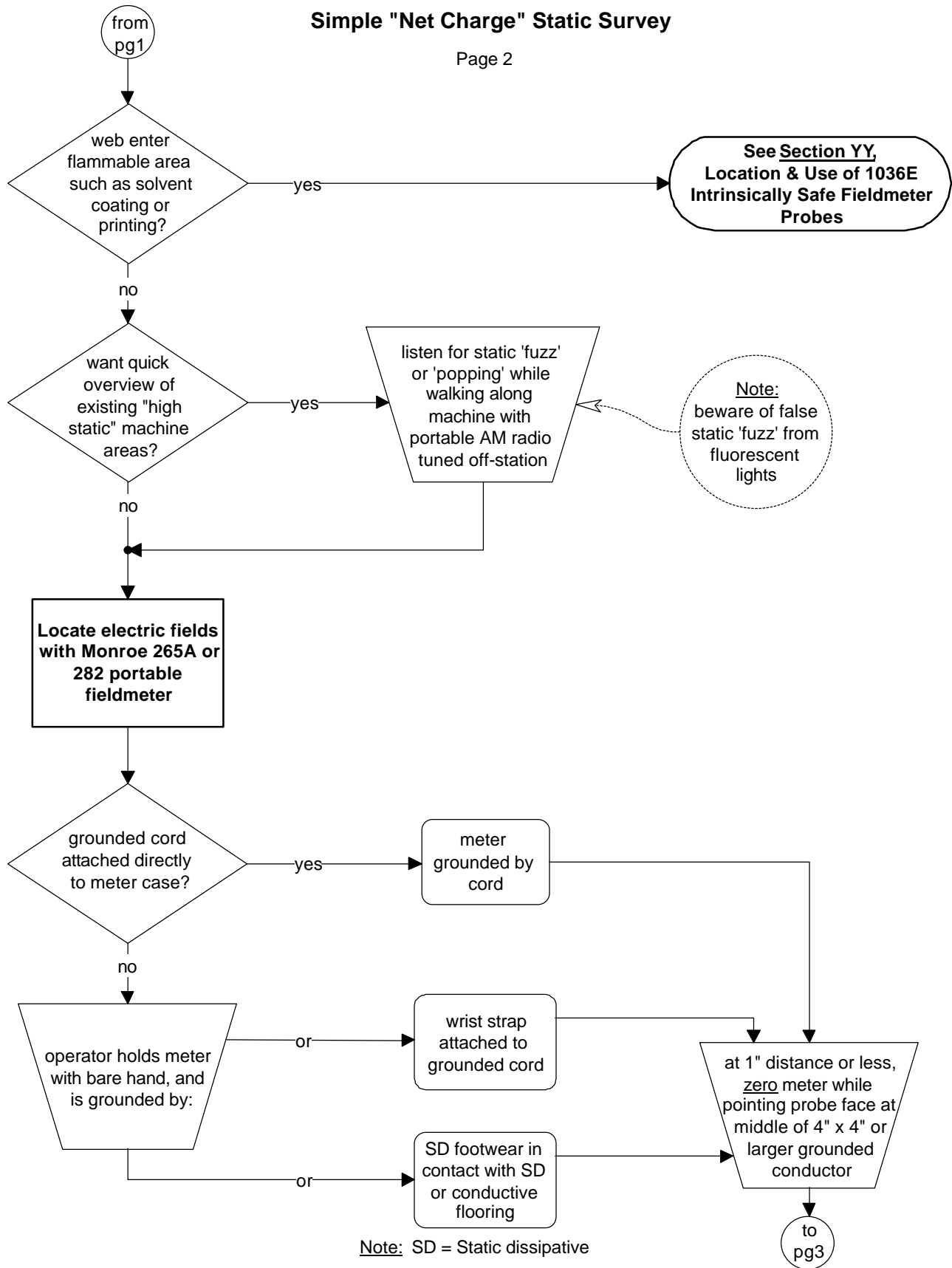

Note: SD = Static dissipative

Simple "Net Charge" Static Survey

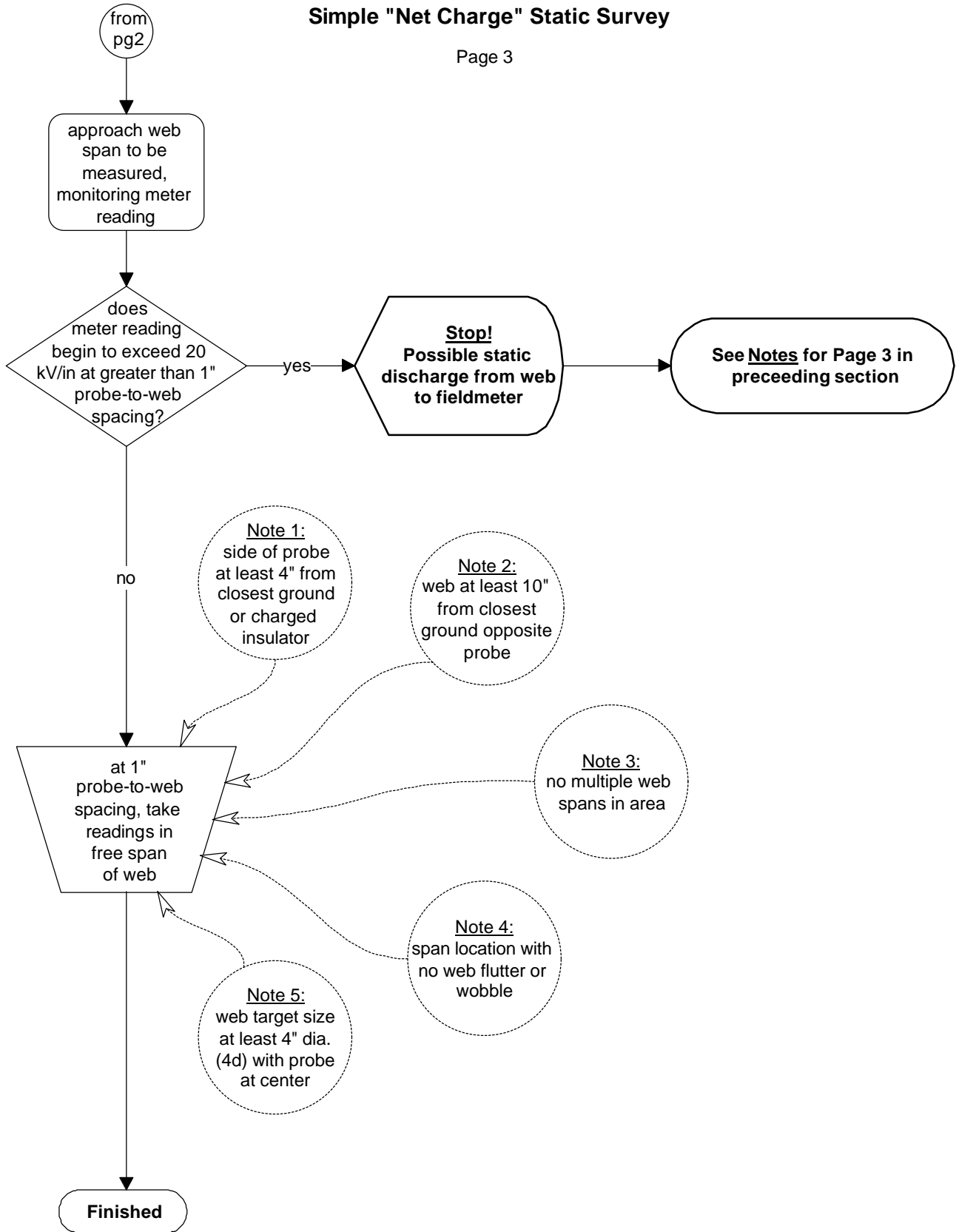

Calculating Web Surface Charge Density

Providing that fieldmeter readings are taken in compliance with the limiting conditions specified above, web surface charge density (charge per unit area, q/A) can be calculated from these readings as follows [2,4]:

$$\text{Surface charge density}(s) = \text{Electric field}(E) \times \text{Permittivity of free space}(e)$$

e.g. for a reading of 5,000 V/in:

$$s (q/A) = \{5,000 \text{ V/in}\} \times \{8.85 \times 10^{-12} \text{ coulomb(C)/volt(V)•meter(m)}\} \text{ or,}$$

$$s (q/A) = 1.74 \times 10^{-6} \text{ C/m}^2, \text{ or } 1.74 \text{ } \mu\text{C/m}^2 \quad \text{where: } \mu = 10^{-6}$$

Relating Web Surface Charge Density To The Real World

It is widely reported in literature and texts that the maximum practical charge density a surface can hold is about $25 \mu\text{C/m}^2$. Discharges to nearby conductors and surrounding air are responsible for this limitation. It has been stated by Seaver [2] that “Industry has used an unwritten ‘rule-of-safety’, known as the 5000 Volts Rule, to keep static charge on a web at a reasonable level. The rule states that if the potential on a free-span of web is kept below 5000 volts, then the web should remain free of static discharge problems within that free-span. This rule was established when fieldmeters were usually specified to be operated at 2.5 cm (≈ 1 inch) from the web.”

Referring to the charge density calculation in the previous section, where $s = 1.74 \mu\text{C/m}^2$ at $E = 5000 \text{ V/in}$, Seaver [2] states “This charge density is over an order of magnitude below the $25 \mu\text{C/m}^2$ required for a guaranteed discharge from the web. Thus, the 5000 Volts Rule is equivalent to keeping the surface charge density below one tenth the discharge value.” and “The 5000 Volts Rule is a good safety rule for non-conductive webs, but it must be remembered that the measurement needs to be made with the fieldmeter held 2.5 cm from the surface of a true free-span of web. The 5000 Volts Rule ensures the web has a surface charge density that is less than $2 \mu\text{C/m}^2$.”

Lower charge levels, while safe from discharges, may still attract contaminants and cause contamination problems in many processes.

Continuous Monitoring Of Electric Fields In High-Risk Machine/Product Performance Areas

Antistatic measuring and control systems are needed in practice because the conditions for static elimination always change [10].

Permanent fieldmeters are especially necessary in hazardous areas to verify nonhazardous web surface charge density levels. The probes are installed immediately downstream of passive or active ionizers to make sure the ionizers are working correctly. This scenario assumes all rollers but the gravure and impression to be outside the classified area. All electrically powered equipment installed in these classified locations must be approved for the solvent atmosphere in which they are located, so both the probes and ionizers must be approved for the classified areas in which they are installed.

For details on continuous monitoring, see the next document in this series, APNE-0016, Static Control in Web Converting.

III References

- [1] Crowley, J.M., *Fundamentals of Applied Electrostatics*, Wiley-Interscience, New York (1985)
- [2] Seaver, A.E., "Analysis of Electrostatic Measurements on Non-Conducting Webs", *J. Electrostatics*, Vol. 35, Elsevier, New York (1995)
- [3] Application Note APNE-0003, "Fieldmeter Measurement Techniques Using Monroe Electronics Model 1036 Probes", <http://www.monroe-electronics.com/>.
- [4] Taylor, D.M. and Secker, P.E., *Industrial Electrostatics: Fundamentals and measurements*, Research Studies Press, John Wiley (1994)
- [5] Maurer, B., Glor, M., Lutgens, G. and Post, L., "Hazards Associated with Propagating Brush Discharges on Flexible Intermediate Bulk Containers, Compounds and Coated Materials", *Electrostatics '87*, Inst Phys Confr Series No. 85, London (1987)
- [6] Vosteen, W.E., Monroe Electronics, Inc., "A Review of Current Electrostatic Measurement Techniques and Their Limitations" presented at the Electrical Overstress Exposition, April 24-26, 1984
- [7] TANTEC Static Elimination Guidebook, *A Guidebook On Using Electrostatics For the Elimination of Static Charges on Industrial Surfaces*, Schaumburg, IL (1998)
- [8] Seaver, A.E., "Moving Ground Plane Electrostatic Fieldmeter Measurements", *J. Electrostatics*, Vol. 42, Elsevier, New York (1997)
- [9] Haase, H., *Electrostatic Hazards: Their Evaluation and Control*, Verlag Chemie, New York (1977)
- [10] Horváth, T. and Berta, I., *Static Elimination*, Research Studies Press, Chichester (1982).